

PANZERI

Arena Acoustic

220-240V AC dimmable (DALI/Push DIM)

L05617.100.0502



bronze



Data sheet

CODE	L05617.100.0502
SYSTEM POWER CONSUMPTION	51W
EFFICACY	28.12lm/W
LIGHT SOURCE	LED
LIGHT SOURCE LIFETIME	L70 (B50) 60.000h
COLOUR TEMPERATURE	2700K Ra>90
LIGHT DISTRIBUTION	diffused
POWER SUPPLY	220-240V AC
FREQUENCY	50/60Hz
ELECTRICAL CONFIGURATION	dimmable (DALI/Push DIM)
DRIVER	integrated included
NOMINAL LUMINOUS FLUX	5670lm
LUMEN OUTPUT	1434lm
EFFICIENCY	25.3%
GLARE RATING	UGR < 19
WEIGHT	5,86 Kg
PROTECTION DEGREE	IP20
COLOUR TOLLERANCES	SDCM 3
PACKING DIMENSIONS	107,0 x 107,0 x 11,0 cm



Suspension lighting fixture for interiors, with direct light emission. Bended extruded aluminium structure in white, black, bronze, mat brass or titanium polyacrylic paint. Sound absorbing PET panel Slalom "MILLERIGHE" with "PETfelt" finish, made of polyester obtained from the recycling of plastic bottles, or "PETfabric", made of recycled polyester, in "neutral grey" (white version), "morning green" (black version), "brick" (bronze version), "milk" (mat brass version) or "mud" colour (titanium version); high acoustic comfort and fire rating B-s2, d0; suitable for Breeam, Leed, Well and Fitwel building certifications. Extruded polycarbonate diffuser with opaline finish. 5m (196,9") long steel suspension cables. 5m (196,9") long power cable in transparent PVC. Power canopy with pickled sheet metal ceiling bracket and covering in white, black, bronze, mat brass or titanium polyacrylic paint.

Technical drawing

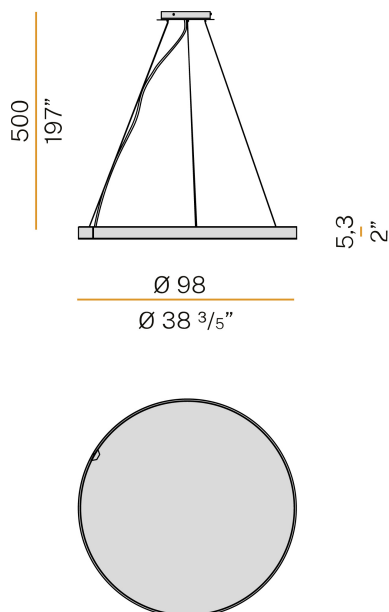

Polar diagram

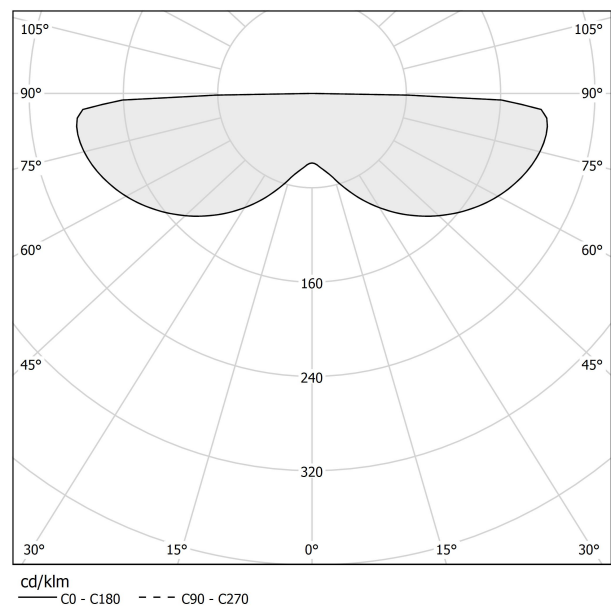

PANZERI

Arena Acoustic

Accessories / acoustics

YPA05602.030

Sound absorbing panel for increasing acoustic performance [Alpha W coefficient (aw) 0.9]. Fixture total height 6,5cm (2 5/9")

